

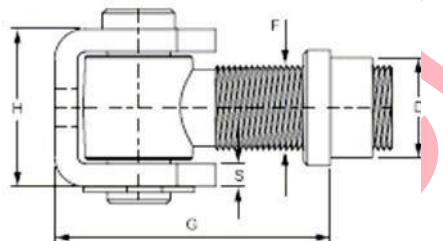

Systemy **KOVANIA KRÍDLOVÝCH BRÁN A VRÁT**

Pánty navarovacie i k našrôbovaniu rôznych rozmerov bez i vr. dvoch typov základní.



	F	H	S	G	D
PA M18	M18	39	6	min.41	23
PA M20	M20	39	6	min.45	25
PA M22	M22	41	6	min.47	28
PA M24	M24	47	6	min.58	29

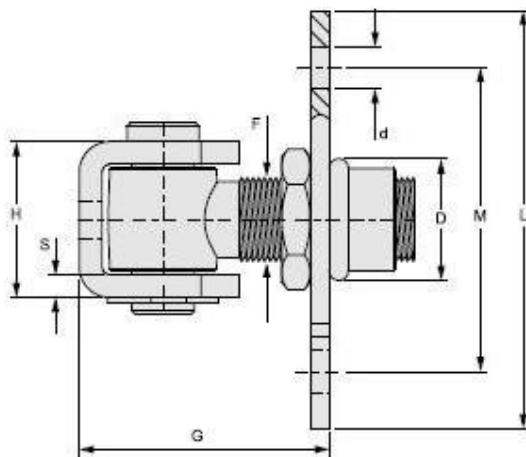

	F	H	S	G	D	L	M
PAZ M18	M18	39	6	50-60	28	90x90	64x64
PAZ M20	M20	39	6	51-66	28	100x100	74x74
PAZ M22	M22	41	6	55-72	32	110x110	80x80
PAZ M24	M24	47	6	63-78	32	120x120	90x90

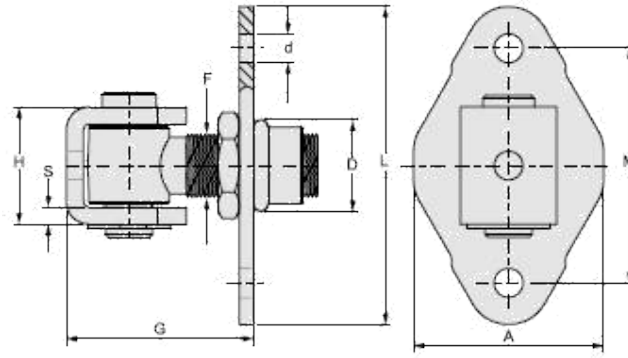

	F	H	S	G	D	L x A
PAD M18	M18	39	6	50-60	28	100x60
PAD M20	M20	39	6	51-66	28	100x74
PAD M22	M22	41	6	55-72	32	122x73
PAD M24	M24	47	6	63-78	32	122x90

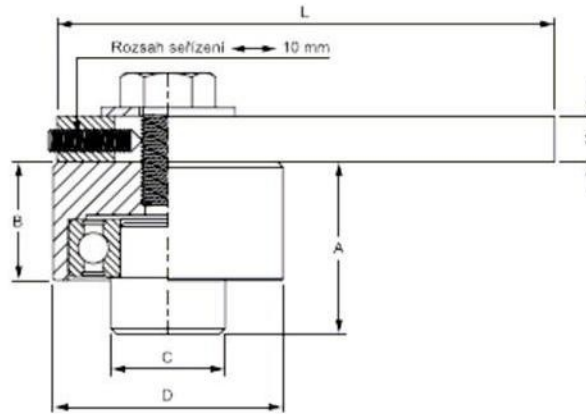

	D	L	S	A	B	C
PAH 40	40	90	8	30	21	25

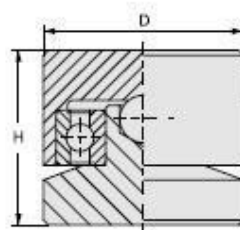

	D	H
PAD 40	40	35